

IF IN DOUBT ASK

ITEM NO.	PART NUMBER	DESCRIPTION	QTY.
1	0746-003-1	M/STEEL LOCK TOP PLATE - LH	1
2	0746-003-2	M/STEEL LOCK BOTTOM PLATE - LH	1
3	0746-003-3	BRASS TONGUE - LH	1
4	0746-003-4	M/STEEL END PLATE	1

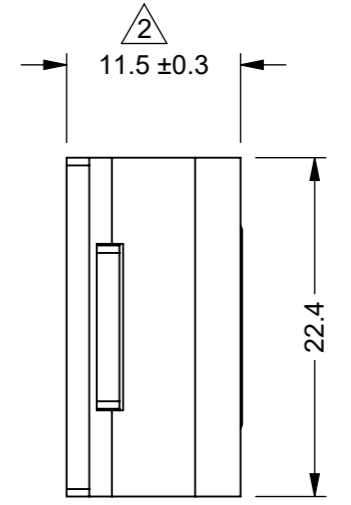
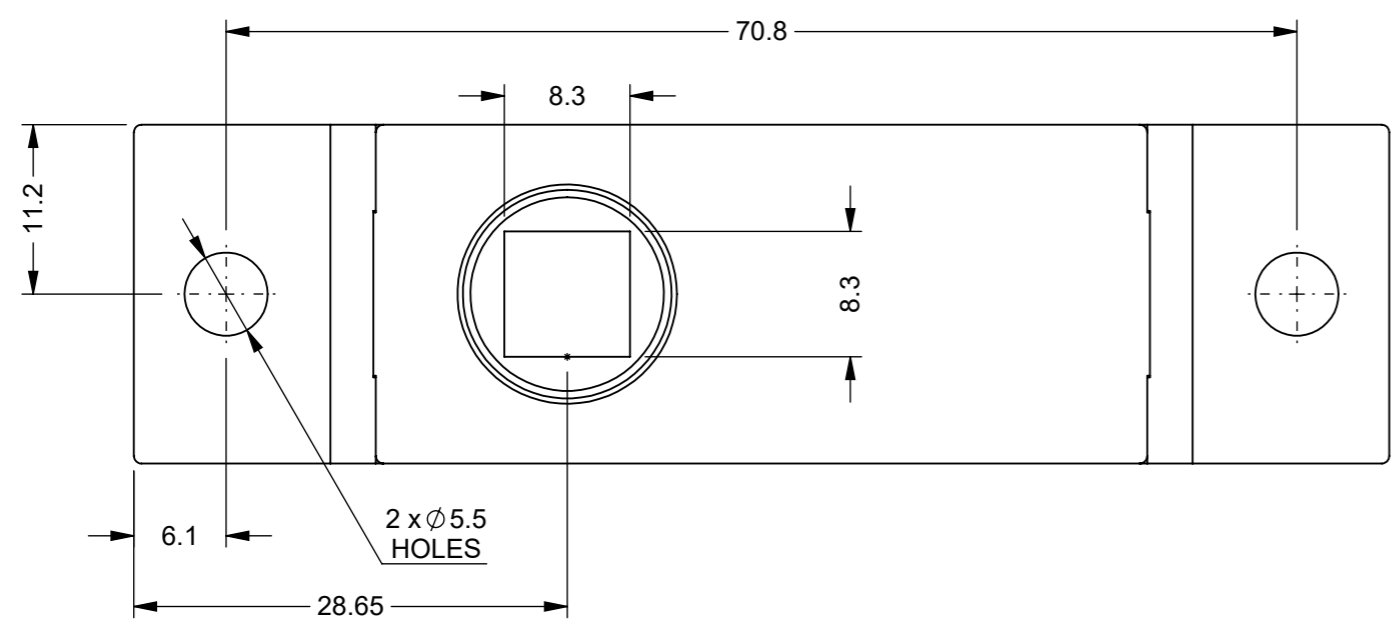
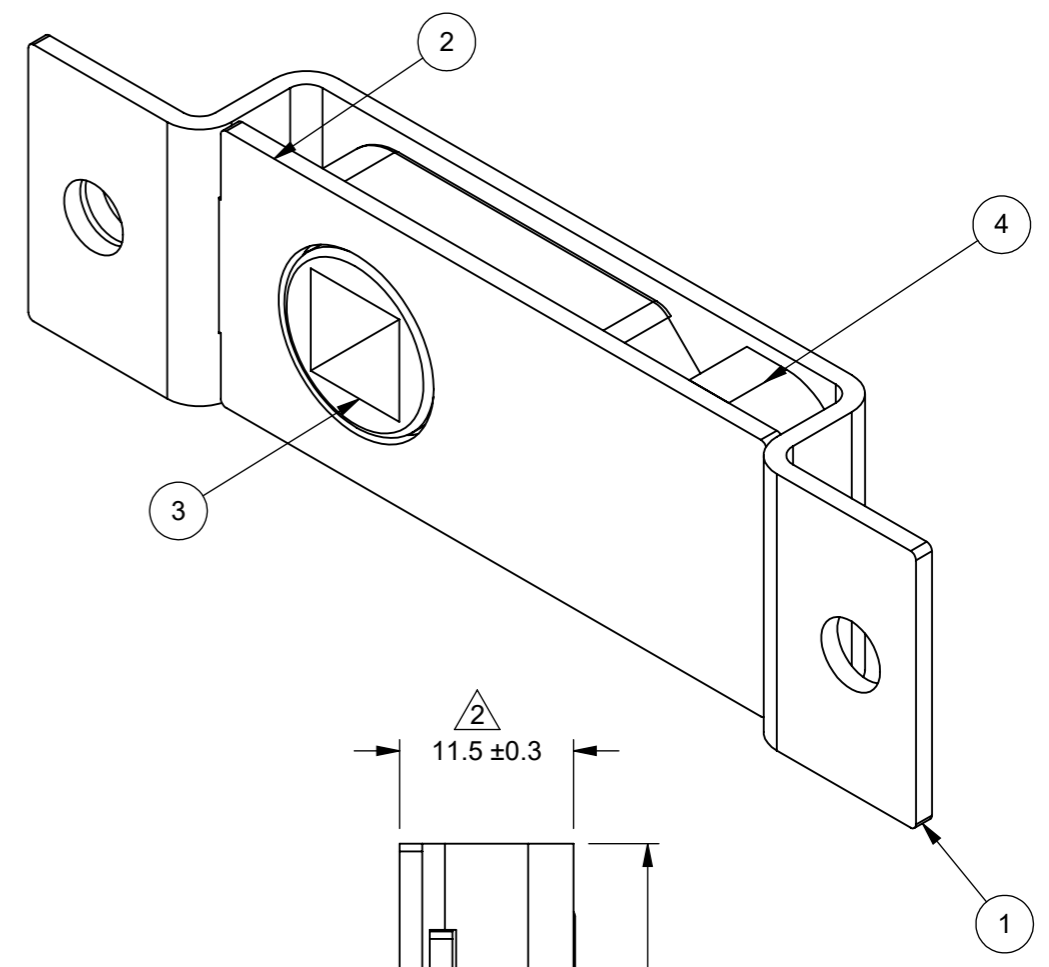
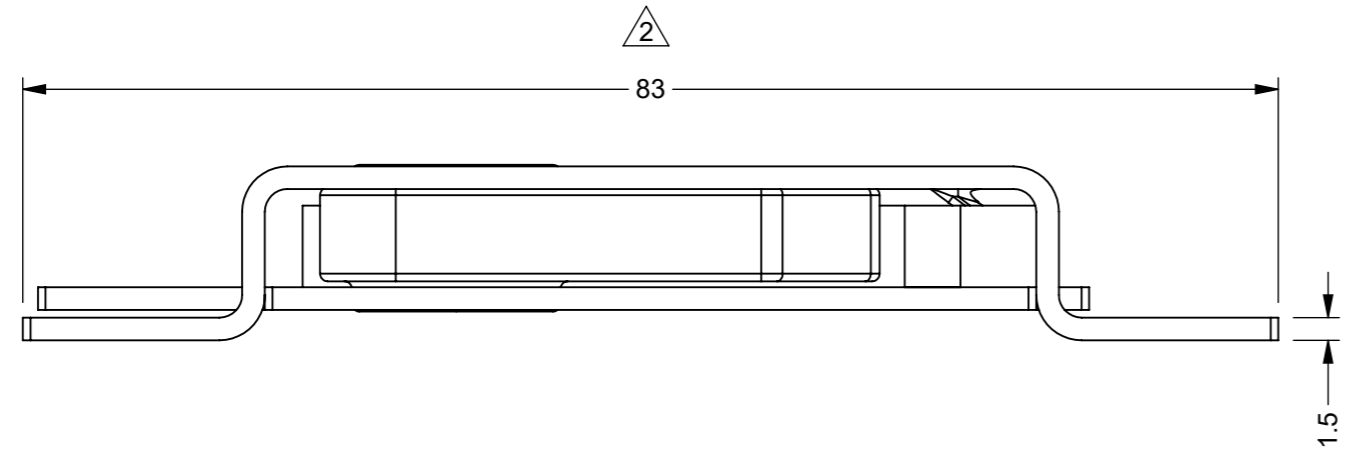

ZONE	REV.	DESCRIPTION	DATE	APPROVED
B6, C2	2	ECR 16 -OVERALL LENGTH INCREASED, TOLERANCE ADDED	29/02/2024	U.F

REVISIONS

TOLERANCES		SURFACE FINISH 1.6µm Ra	
0.5 - 6	= ±0.1mm	FILLET RADII	0.5 TO 1.0
6 - 30	= ±0.2 mm	SQUARENESS	0.05 IN 25
30 - 120	= ±0.3 mm	PARALLELISM	0.05 IN 25
120 - 400	= ±0.5 mm	RUNOUT	0.1
400 - 1000	= ±0.8 mm	ANGLES	±0.5°
1000 - 2000	= ±1.2 mm		
2000 - 4000	= ±2.0 mm		

MATERIAL: SEE TABLE	DRAWN BY: UF	DESCRIPTION: M/STEEL BUDGET LOCK - RH		A3	
MASS: 0.08	CHECKED BY: A.P	NUMBER: 0746-004	REVISION: 2		SHEET: 1 of 1
FINISH: SEE TABLE	APPROVED BY: A.P	ORIGINATION DATE: 29/02/2024	SCALE : PROPORTIONAL - DO NOT SCALE REF SCALE 2:1 WHEN PRINTED ON A3		



PROPRIETARY RIGHTS ARE INCLUDED IN THE INFORMATION DISCLOSED HEREIN. NEITHER THIS DOCUMENT NOR ANY INFORMATION DISCLOSED SHALL BE REPRODUCED, USED, TRANSFERRED TO OTHER DOCUMENTS, OR DISCLOSED TO OTHERS FOR ANY PURPOSE INCLUDING MANUFACTURING UNLESS SPECIFICALLY AUTHORISED IN WRITING. REMOVE ALL SHARP EDGES AND BURRS PART FINISHING AND MARKING TO CESF001

